

Längsschnitt 2:1
cross-cut view

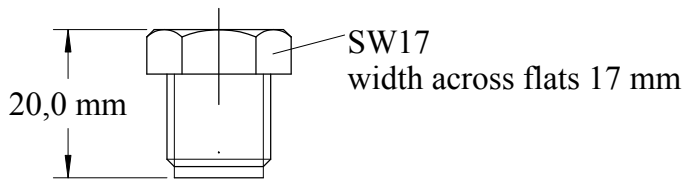
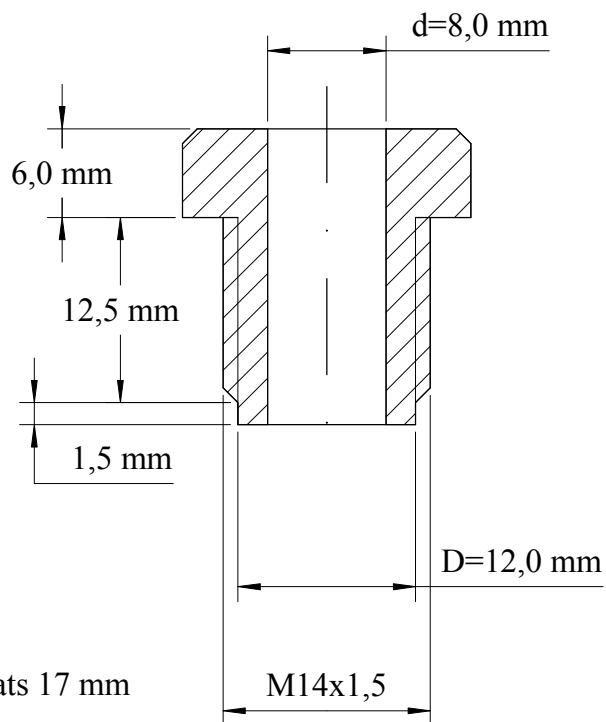

				Allgemein- toleranzen gem. ISO 2768		Maßstab ca. 1:1		Gewicht		
						Werkstoff 1.4571				
				Datum	Name	Verschraubung M14x1,5 m. Bohrung external thread M14x1.5 male + through hole Zg 10226 Art.-Nr. 40020				
				Bearb.	14.03.2011					S. Carstens
				Gepr.						
				Norm						
				TurboCAD16.1						
				EngineSens Motorsensor GmbH D-68519 Viernheim Tel. 0049-6204-986 08 23 Fax 0049-6204-986 08 25						
Index	Änderung	Datum	Name			Blatt 1/1				